

ROTAN® ED

Environmental Duty Pumps

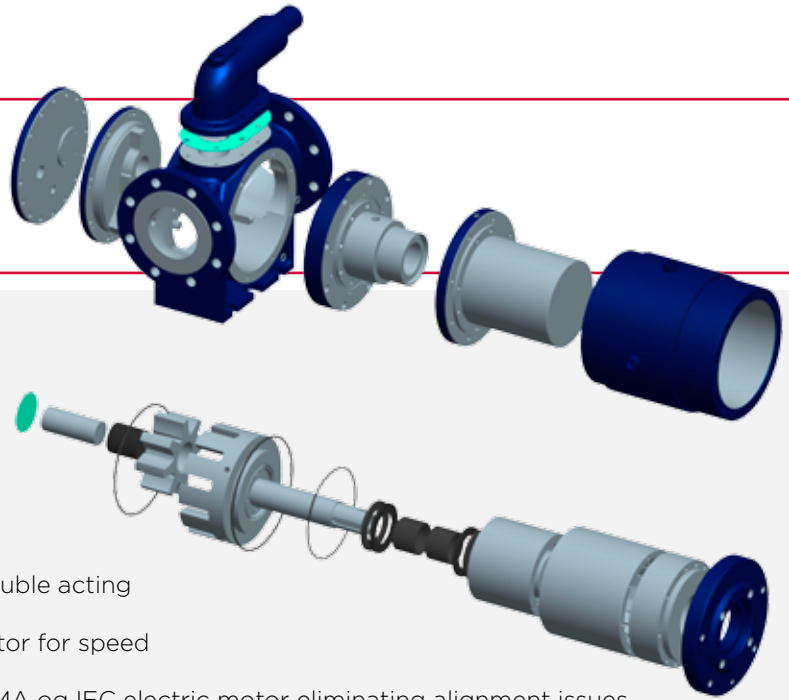

Key features and benefits

- Reversible direction of flow with double acting relief valve option available
- Coupled direct to NEMA or IEC motor for speed up to 1750 rpm
- Directed coupled gearbox with NEMA og IEC electric motor eliminating alignment issues
- Adjustable rotor end clearance without opening the system to the atmosphere
- Torque capabilities in excess of 800 ft-lb
- Flow rates max. 90 m³/h with differential pressure up to max. 16 bar.
- Iron, Steel and Stainless Steel construction
- Tungsten Carbide abrasive wear materials are available for abrasive duty applications



Magnetically coupled pumps for ultimate protection against leakage.

As only minimal maintenance is necessary, ED pumps will be a very economical solution compared with traditionally sealed pumps, especially where the application requires the use of double mechanical shaft seals.

Often these applications are very different, resulting in the seals and support system requiring regular attention and/or replacement. Thus, the life cycle costs for ED pumps are generally much lower than for pumps using two seals.

Available with 90° angular configuration.

Materials	Cast iron, carbon steel or stainless steel
Capacity Range	Up to 90 m ³ /h / 396 gpm
Speed	Up to 1750 rpm
Differential Pressure	Up to 16 bar / 232 psi
Suction Lift	Up to 0,5 bar / 7.25 psi vacuum while priming Up to 0,8 bar / 11.6 psi vacuum while pumping
Viscosity Range	Up to 10,000 cSt
Temperature	Up to 250°C / 482°F
Common Applications: Where no leakage, liquid or gaseous, is allowed.	
Pumping of: Isocyanate, Solvents, Hazardous organic liquids, Printing ink, Resin, Pitch, Alkyd resin, Soyabean oil, Linseed oil, Monomers, Polyol, Corn syrup	

For more information on Industry solutions, please visit www.desmi.com

DESMI

Selection of Pump size

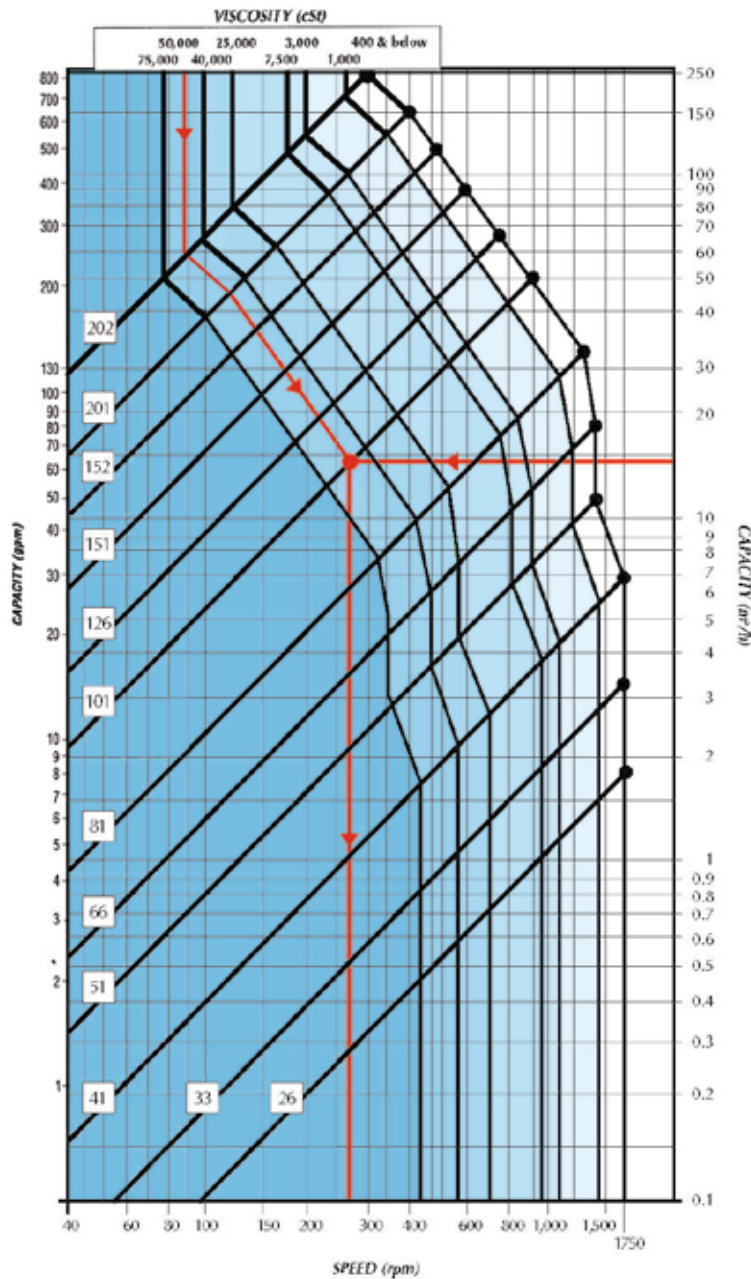

PLEASE NOTE!

ED: Capacity curve up to 151
 GP: Capacity curve up to 101

To select the pump size with this table, you should only know:

- The capacity
- The viscosity

We start at the top of the table with the viscosity, and draw a line down, staying within the colour of the selected viscosity range (see example).

Then we start at the right of the table, drawing a horizontal line starting with the required capacity (see example).

The point where these two lines meet determines the pump size, defined by the diagonal lines in the table. If you do not hit one of these pump lines exactly, increase the capacity a bit. The speed is found vertically below the point of intersection (see example).

The maximum speed of each pump is found vertically below the end of each pump line (indicated with the small black dot). This maximum speed must be reduced to max. 50% when pumping strongly abrasive liquids or emulsions.

When the differential pressure is known, the shaft power is calculated by:

$$E(KW) = 0,07 \times \text{flow (m}^3/\text{h)} \times \text{differential pressure (bar)}$$

The requested shaft power has to be increased by up to 35% when using a small ROTAN® pump in combination with high viscosity (Over 10,000 cSt).

The requested shaft power has to be decreased by up to 35% when using a big ROTAN® pump in combination with low viscosity (Under 500 cSt).